

ÜRÜN MONTAJ KILAVUZU

SPACE-7 GENÇ ODASI ŞIFONYER

**SATIŞ SONRASI HİZMET
DESTEK WHATSAPP HATTI**



MONTAJ HAZIRLIK: Tüm paketleri dikkatli bir şekilde açınız. Ürün parçalarını şekil ve boyutlarına göre sınıflandırınız.

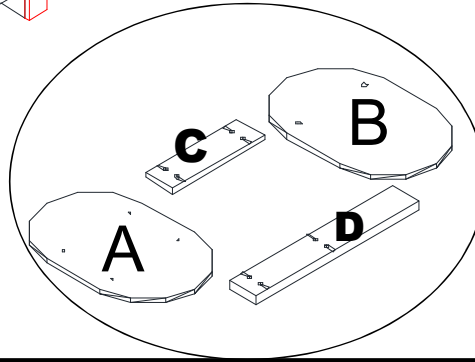
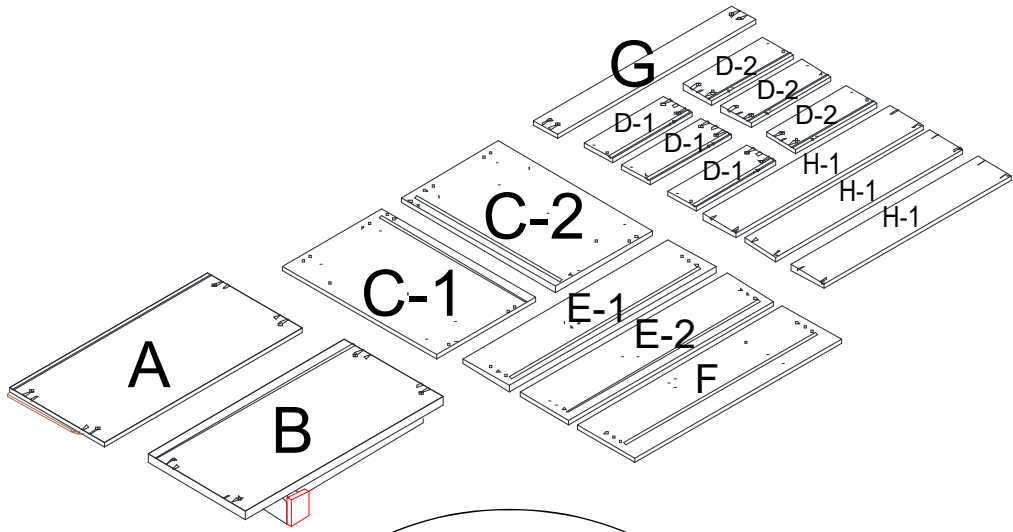

ŞİFONYER AYNA

MONTAJ İÇİN GEREKLİ ALET ÖNERİLERİ: Şarjlı matkap, Yıldız başlı tornavida, Çekiç

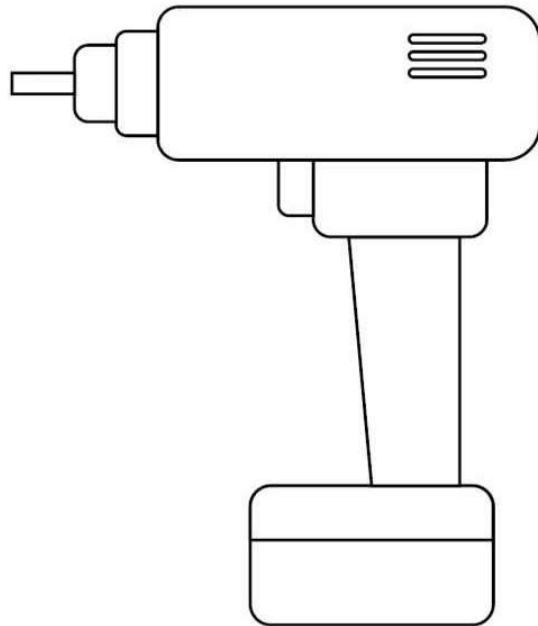
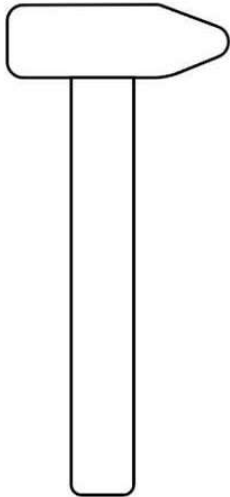

MONTAJ HAZIRLIK: MALZEME POŞET İÇERİĞİ

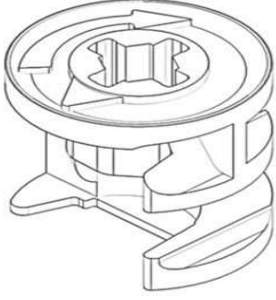

V01

32 ADET MİNİFİX
GÖVDE

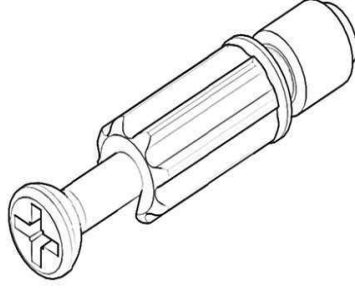

V02

32 ADET MİNİFİX
MİL

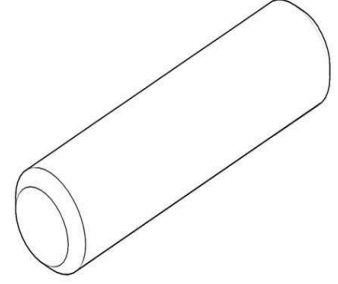

V03

14 ADET PLASTİK
SİYAH KAVELA

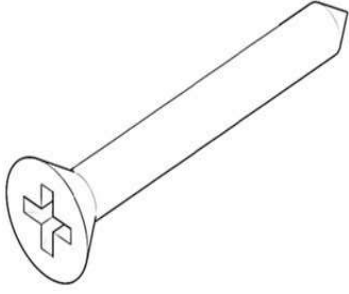

V04

12 ADET
KABİN VİDASI

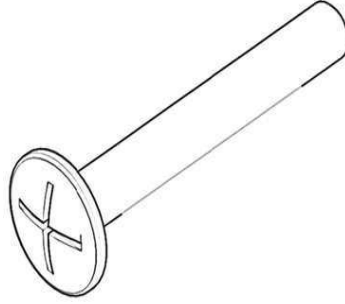

V05

14 ADET
GENİŞ DİŞ KULP VİDASI

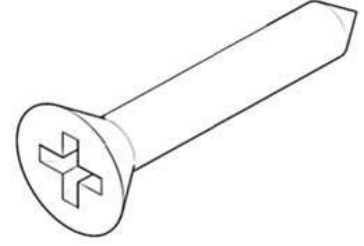

V06

12 ADET
3,5*18 VİDA

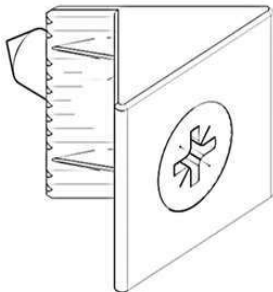

V07

5 ADET
ARKALIK SIKIŞTIRMA

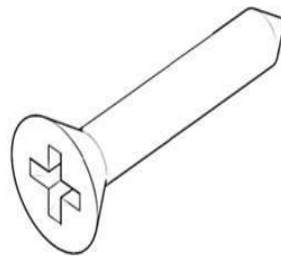

V08

11 ADET
3,5*25 ARKALIK VİDASI

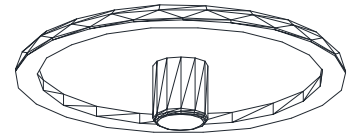

V09

32 ADET
MİNİFİX TIPASI

MONTAJ HAZIRLIK: MALZEME POŞET İÇERİĞİ

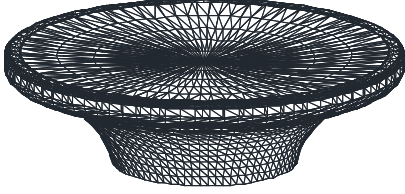

V10

1 ADET
OVAL KULP

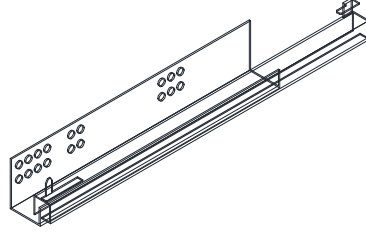

V11

3 TK
35 CM FRENLİ RAY

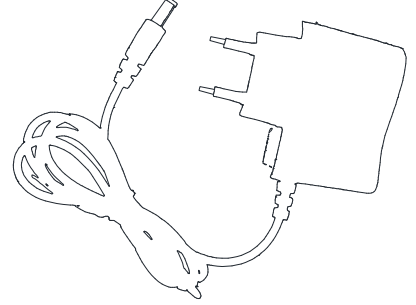

V12

1 ADET
LED ADAPTÖRÜ

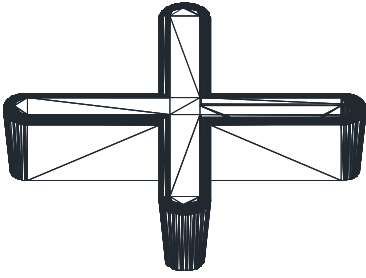

V13

3 ADET
X KULP

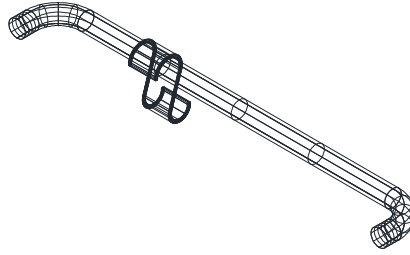

V14

2 ADET
YAN ASKILIK VE KANCA

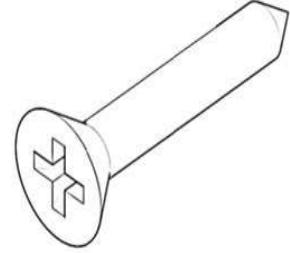

V15

2 ADET
3,5*30 MDF KULP VİDASI

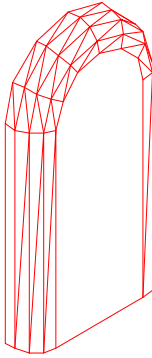

V16

1 ADET
ANTRASİT MDF KULP

MONTAJ AŞAMALARI - 1

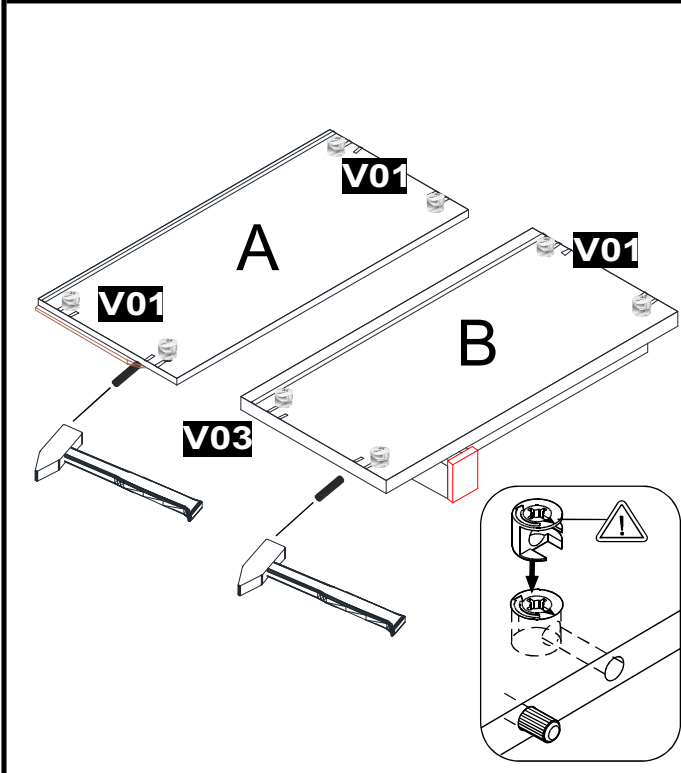

A VE B PARÇALARINA (ALT VE ÜST TABLA) ŞEKİLDE GÖRÜLDÜĞÜ GİBİ **V01 VE V03** KODLU MALZEMELERİ TAKINIZ.

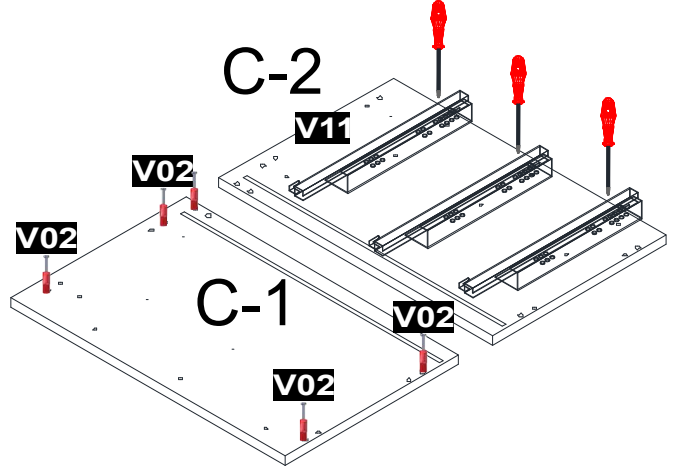

C-1 VE C-2 PARÇALARINA ŞEKİLDE GÖRÜLDÜĞÜ GİBİ **V11** KODLU MALZEME (RAY) **V06** KODLU VİDA İLE BAĞLAYINIZ. ARDINDAN **V02** KODLU MALZEMEYİ TAKINIZ.

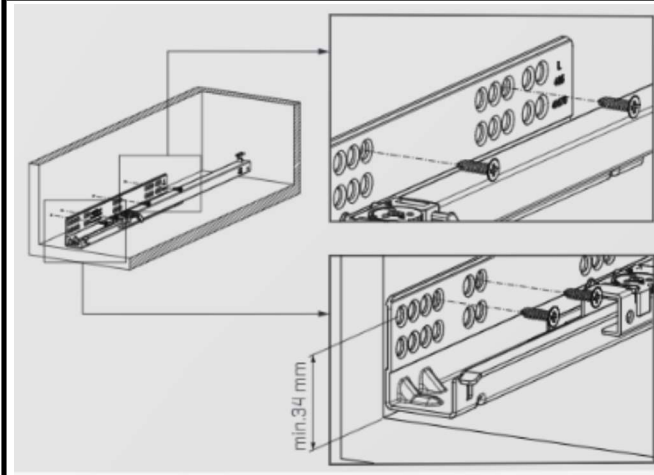

260 mm

285-310-335

360-385-410 mm

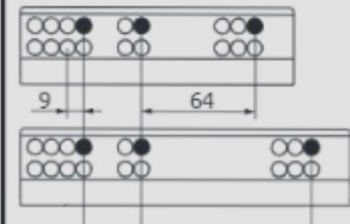

V11 KODLU MALZEME (FRENLİ RAY) BAĞLANTI KLAUVUZU.

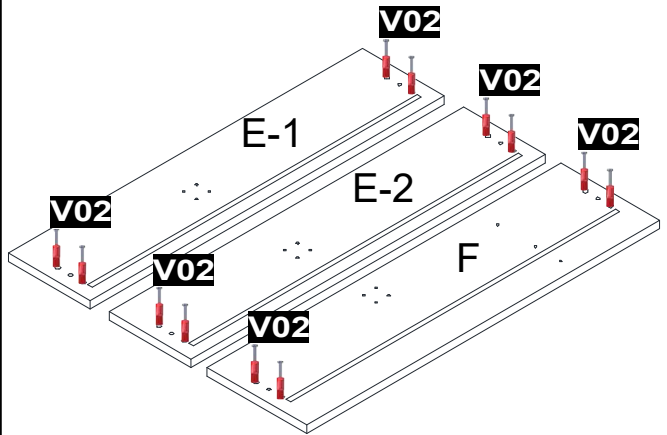

E-1 , E-2 VE F PARÇALARINA (ÇEKMECE ÖN YÜZ) ŞEKİLDE GÖRÜLDÜĞÜ GİBİ **V02** KODLU MALZEMEYİ TAKINIZ. (**F** KODLU PARÇA EN ALT ÇEKMECEDİR)

MONTAJ AŞAMALARI - 2

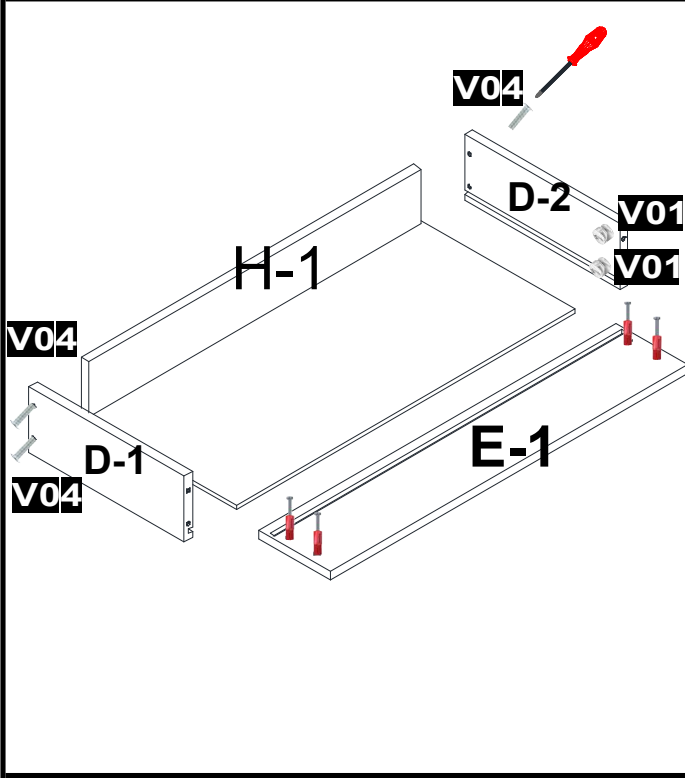

ŞEKİLDE GÖRÜLDÜĞÜ GİBİ **E-1** PARÇASINA **V02** KODLU MALZEMEYİ TAKINIZ. ARDINDAN **D-1 VE D-2** PARÇALARINI **E-1** PARÇASINA TAKINIZ. DAHA SONRA KANALLARDAN ARKALIK PARÇASINI GEÇİRİNİZ. SON OLARAK **H-1** PARÇASINI **V04** KODLU MALZEMELER İLE BİRLEŞTİRİNİZ.

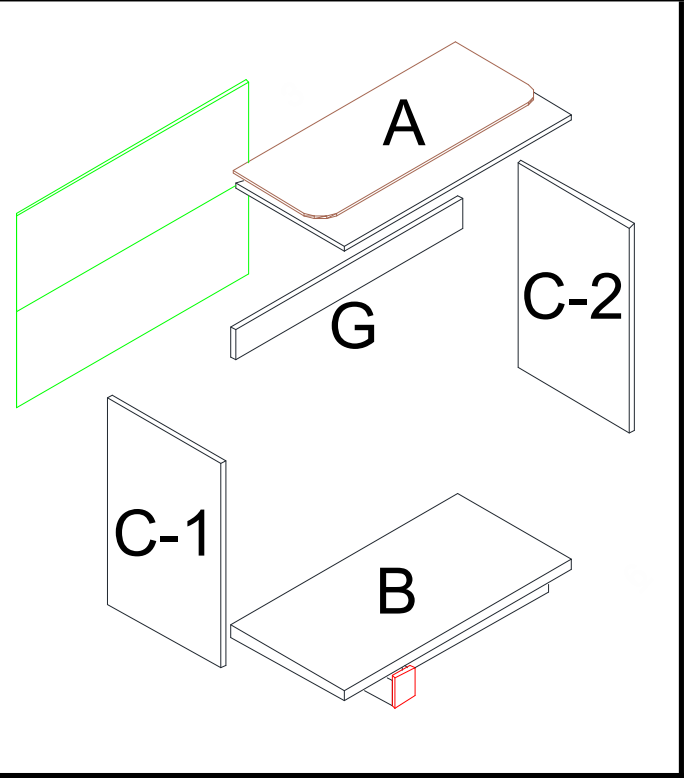

ŞİFONYER GÖVDE MONTAJI İÇİN SIRASIYLA **B, C-1, G, A, C-2** PARÇALARINI TORNAVİDA YARDIMI İLE MİNİFIX GÖVDELERİNİ SAAT YÖNÜNDE SIKARAK BİRLEŞTİRİN.

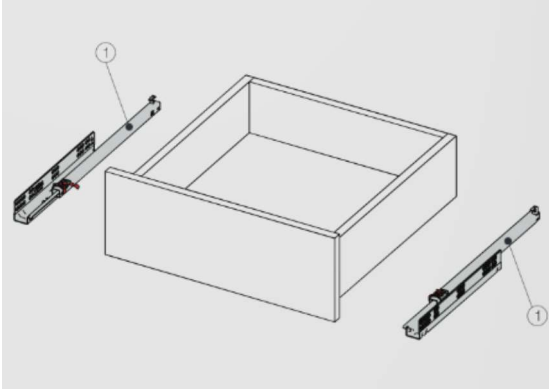
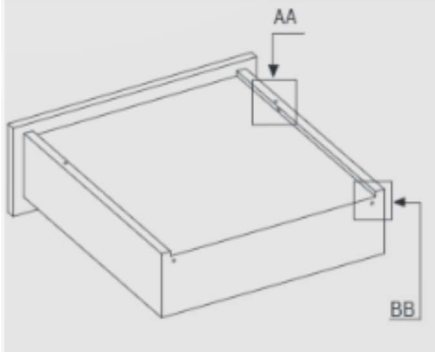

ÇEKMECE KUTULARI OLUŞTURULDUKTAN SONRA RAY PİMLERİ 1. ŞEKİLDE GÖSTERİLEN DELİKLERE DENK GELECEK ŞEKİLDE 2. RESİM TUTUŞ POZİSYONUNDA RAYLARA YERLEŞTİRİNİZ VE ALT KISIMDAKİ PİMLERİ KİLİTLEYİNİZ.

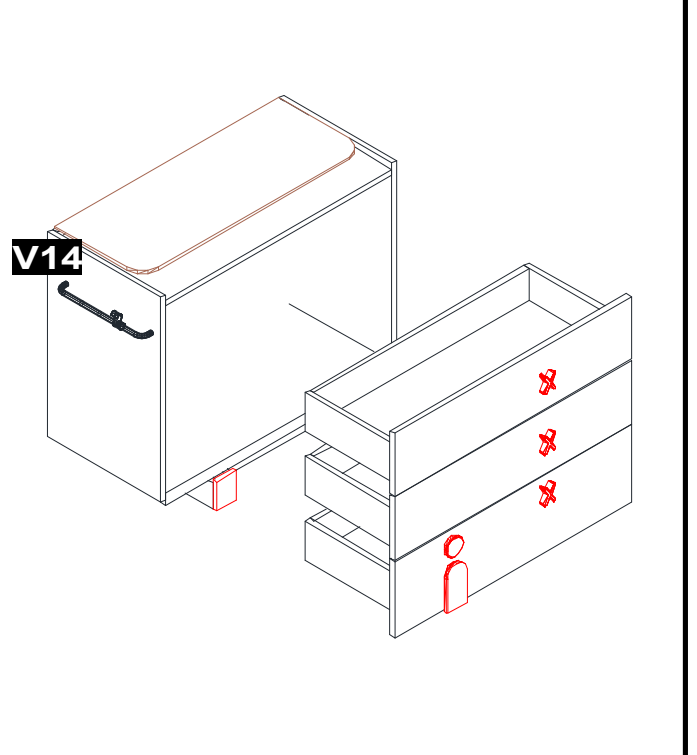

SON OLARAK MONTAJI YAPILAN ÇEKMECELERİN RAY BAĞLANTILARINI YAPIN. PAKETTEN ÇIKAN ADAPTÖR İLE LED AYDINLATMA BAĞLANTISINI YAPIN.