

ÜRÜN MONTAJ KLAVUZU

PETRA GENÇ ODASI ÇAMAŞIRLIK

**SATIŞ SONRASI HİZMET
DESTEK WHATSAPP HATTI**



MONTAJ HAZIRLIK: Tüm paketleri dikkatli bir şekilde açınız. Ürün parçalarını şekil ve boyutlarına göre sınıflandırınız.

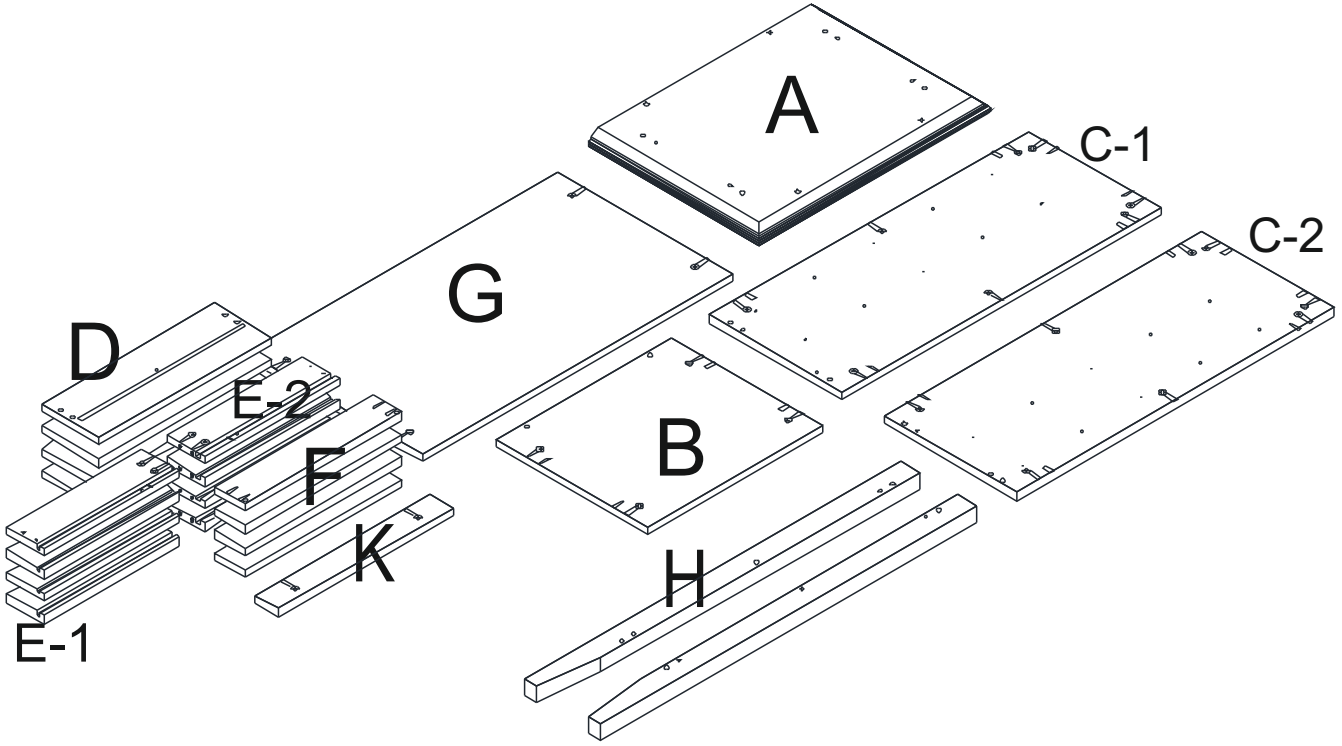

MONTAJ İÇİN GEREKLİ ALET ÖNERİLERİ: Şarjlı matkap, Yıldız başlı tornavida, Çekiç

- A: ÜST TABLA**
- B: ALT TABLA**
- C: SAĞ-SOL YAN TABLA**
- D: ÇEKMECE ÖN**
- E: ÇEKMECE YANLAR**
- F: ÇEKMECE ARKA**
- G: ARKA PANO**
- H: ÖN ARKA AYAK KLAPA**
- K: ÖN BAZA**

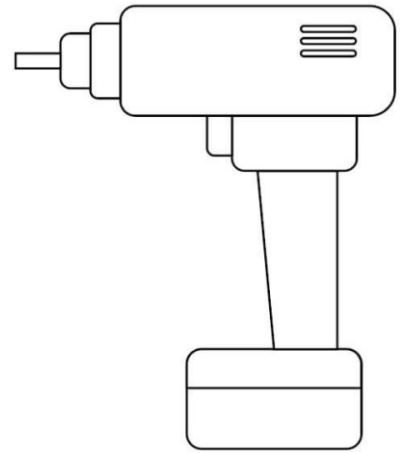
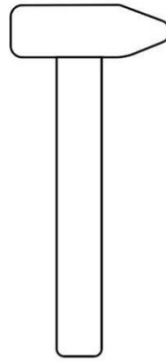

MONTAJ HAZIRLIK: MALZEME POŞET İÇERİĞİ

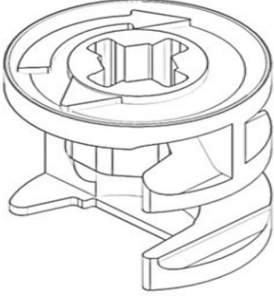

V01

46 ADET MİNİFİX
GÖVDE

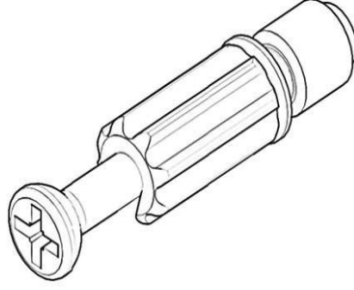

V02

46 ADET MİNİFİX
MİL

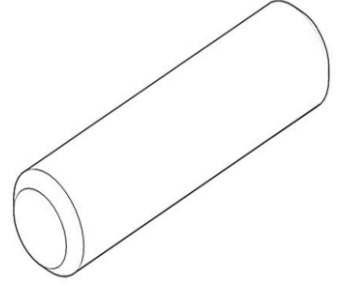

V03

16 ADET PLASTİK
SİYAH KAVELA

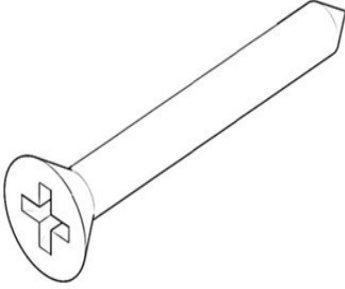

V04

20 ADET
KABİN VİDASI

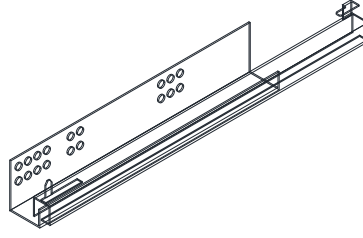

V05

5 TK
35 CM FRENLİ RAY

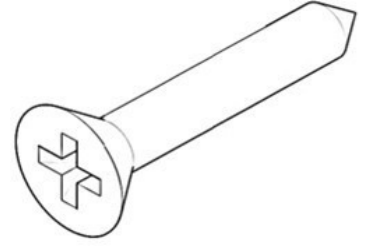

V06

20 ADET
3,5*18 VİDA

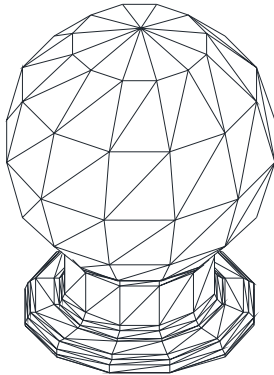

V07

5 ADET TEKLİ KULP

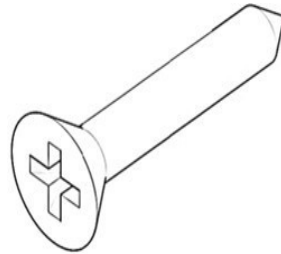

V08

10 ADET
3,5*25 ARKALIK VİDASI

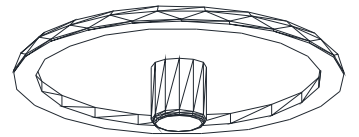

V09

46 ADET
MİNİFİX TIPASI

MONTAJ HAZIRLIK: MALZEME POŞET İÇERİĞİ

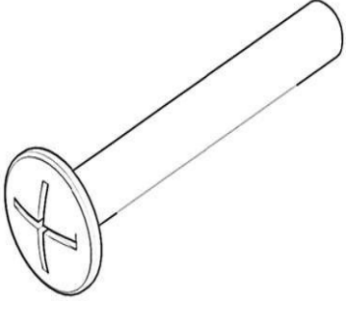

V10

V11

5 ADET 22 LİK KULP
VİDASI

MONTAJ AŞAMALARI - 1

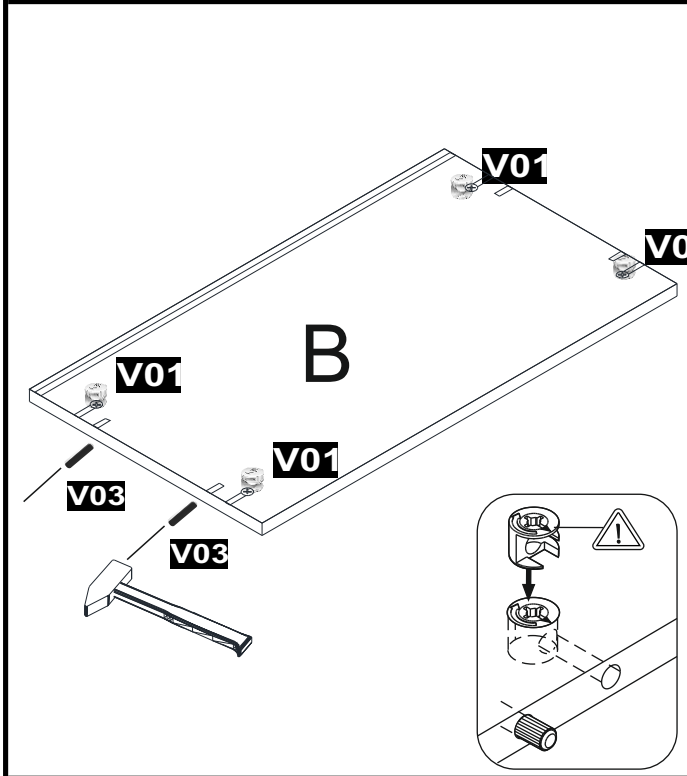

B PARÇASINDA (ALT TABLA) BULUNAN DELİKLERE ŞEKİLDE GÖRÜLDÜĞÜ GİBİ **V01 - V03** KODLU MALZEMELERİ TAKINIZ.

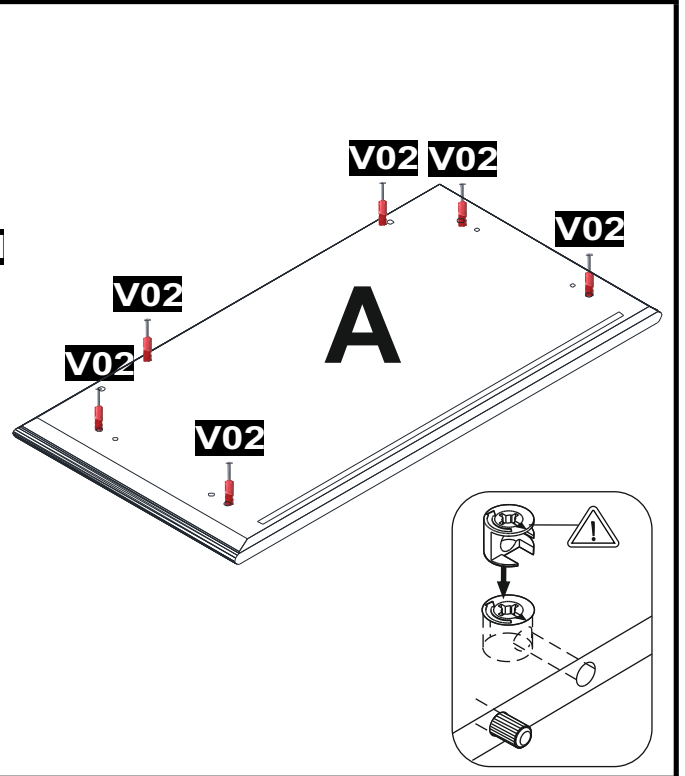

A PARÇASINDA (ÜST TABLA) BULUNAN DELİKLERE ŞEKİLDE GÖRÜLDÜĞÜ GİBİ **V02** KODLU MALZEMELERİ TAKINIZ.

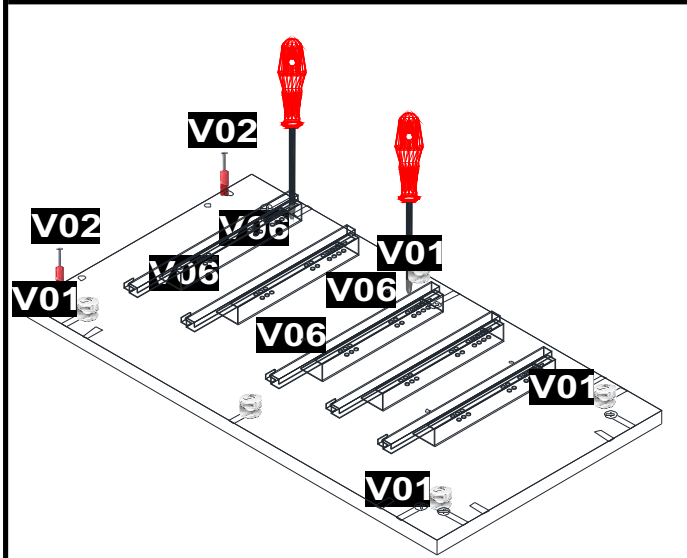

C-1 C-2

C-1 VE **C-2** PARÇALARI (SAĞ-SOL YAN TABLALAR) ÜZERİNDE BULUNAN DELİKLERE **V01** VE **V02** KODLU MALZEMELERİ TAKINIZ. ARDINDAN YAN TABLA ÜZERİNDE BULUNAN VİDALERDEN **V06** VİDALAR İLE RAYLARI BAĞLAYINIZ.

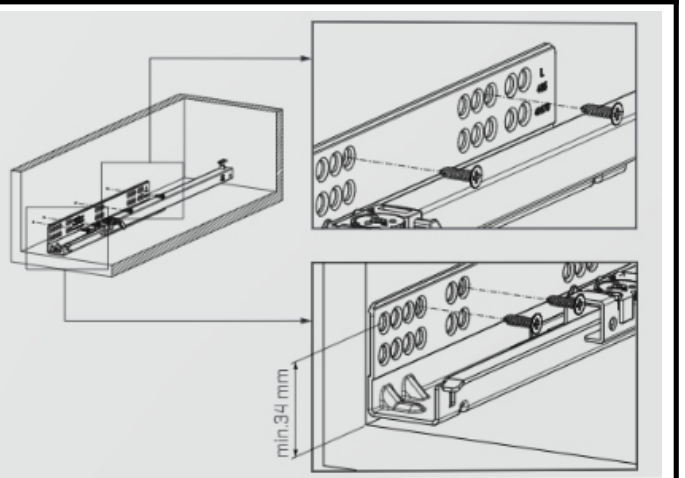

260 mm

285-310-335
360-385-410 mm



V05 KODLU MALZEME (FRENLİ RAY) BAĞLANTI KLAVUZU.

MONTAJ AŐAMALARI - 2

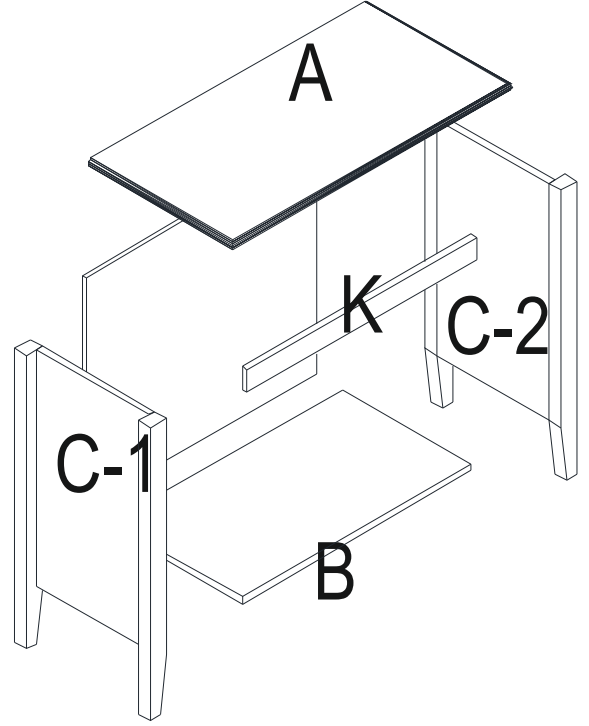
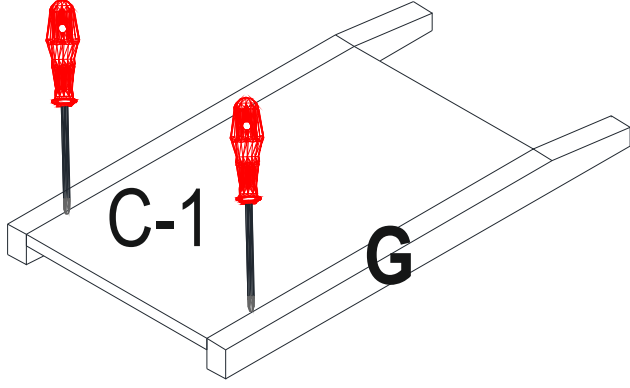

ÇAMAŐIRLIK SAĐ SOL YANLARINI **C-1** PARÇASINI (YAN) KOYUNUZ VE **G** KODLU BAĐLAYINIZ.

ÇAMAŐIRLIK MONTAJ AŐAMASI ŐEKİLDE GÖRÜLEN PARÇALAR İLE SIRASIYLA **B, C-1, A-K VE C-2** İLE TOPLAYINIZ.

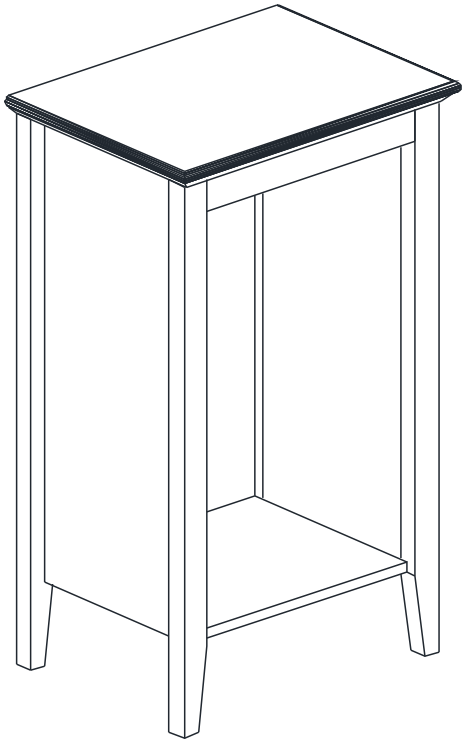

ÇAMAŐIRLIK DIŐ AKSAM MONTAJLANMIŐ SON HALİ

MONTAJ AŞAMALARI - 3

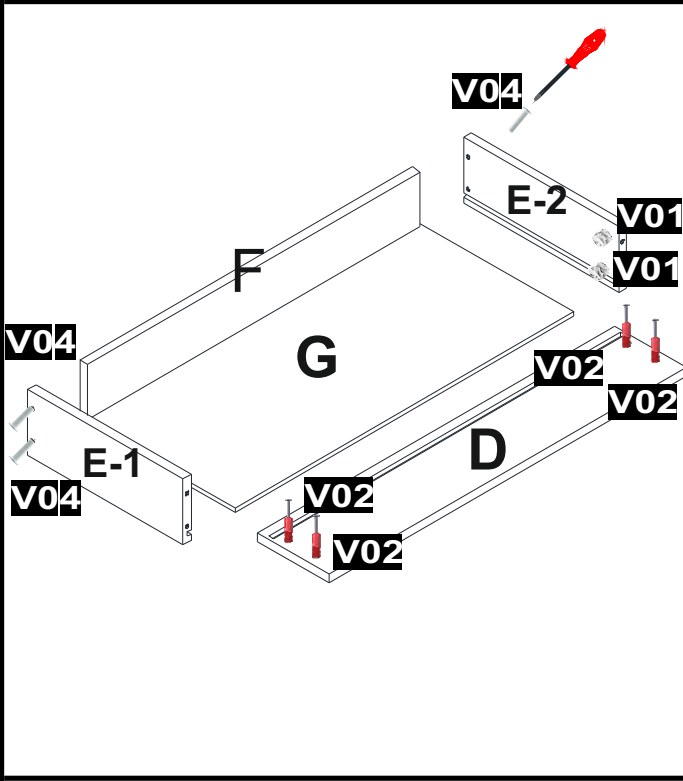

ŞEKİLDE GÖRÜLDÜĞÜ GİBİ **D** PARÇASINA **V02** KODLU MALZEMEYİ TAKINIZ. ARDINDAN **E-1 VE E-2** PARÇALARINI **D** PARÇASINA TAKINIZ. DAHA SONRA KANALLARDAN **G** PARÇASINI GEÇİRİNİZ. SON OLARAK **F** PARÇASINI **V04** KODLU MALZEMELER İLE BİRLEŞTİRİNİZ.

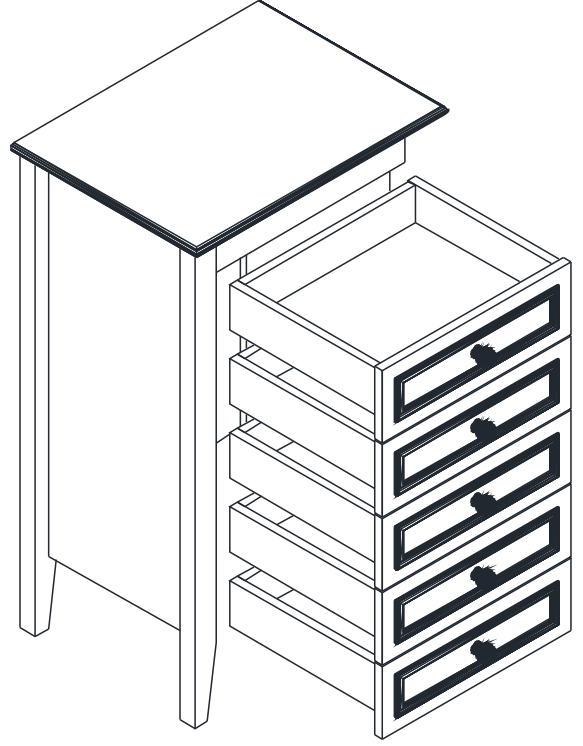

. ÇEKMECE KUTUSU OLUŞTURULDUKTAN SONRA RAY PİMLERİ ALT GÖRSELDE 1. ŞEKİLDE GÖSTERİLEN DELİKLERE DENK GELECEK ŞEKİLDE 2. RESİM TUTUŞ POZİSYONUNDA RAYLARA YERLEŞTİRİNİZ VE ALT KISIMDAKİ PİMLERİ KİLİTLEYİNİZ.

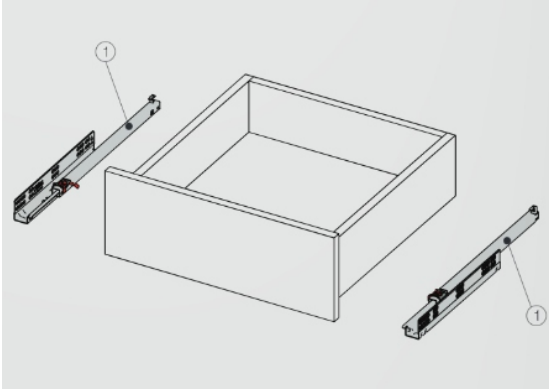
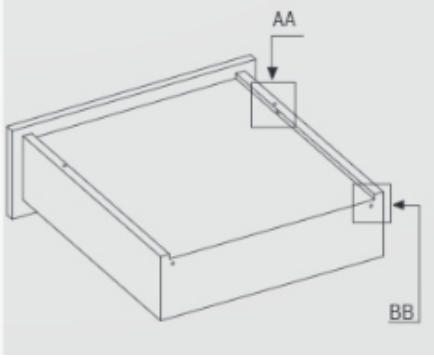

. ÇEKMECE KUTULARI OLUŞTURULDUKTAN SONRA RAY PİMLERİ 1. ŞEKİLDE GÖSTERİLEN DELİKLERE DENK GELECEK ŞEKİLDE 2. RESİM TUTUŞ POZİSYONUNDA RAYLARA YERLEŞTİRİNİZ VE ALT KISIMDAKİ PİMLERİ KİLİTLEYİNİZ.

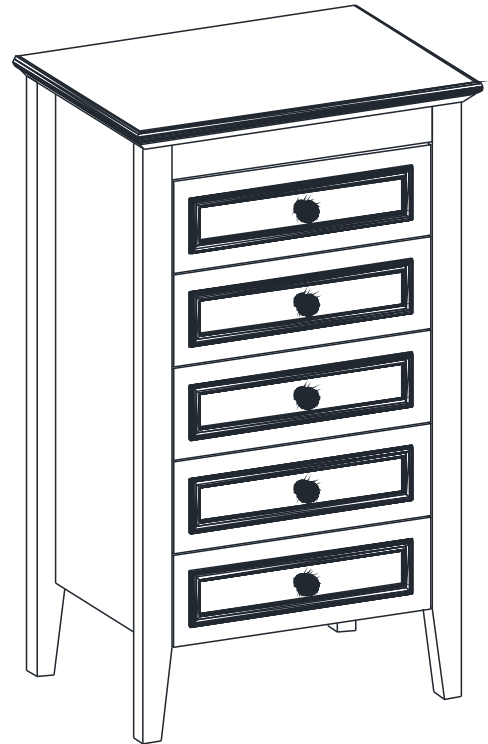

ÇAMAŞIRLIK MONTAJI BİTİRİLMİŞ GÖRSELİ.