

ÜRÜN MONTAJ KLAVUZU

AURA GENÇ ODASI ÇALIŞMA MASASI

**SATIŞ SONRASI HİZMET
DESTEK WHATSAPP HATTI**



MONTAJ HAZIRLIK: Tüm paketleri dikkatli bir şekilde açınız. Ürün parçalarını şekil ve boyutlarına göre sınıflandırınız.

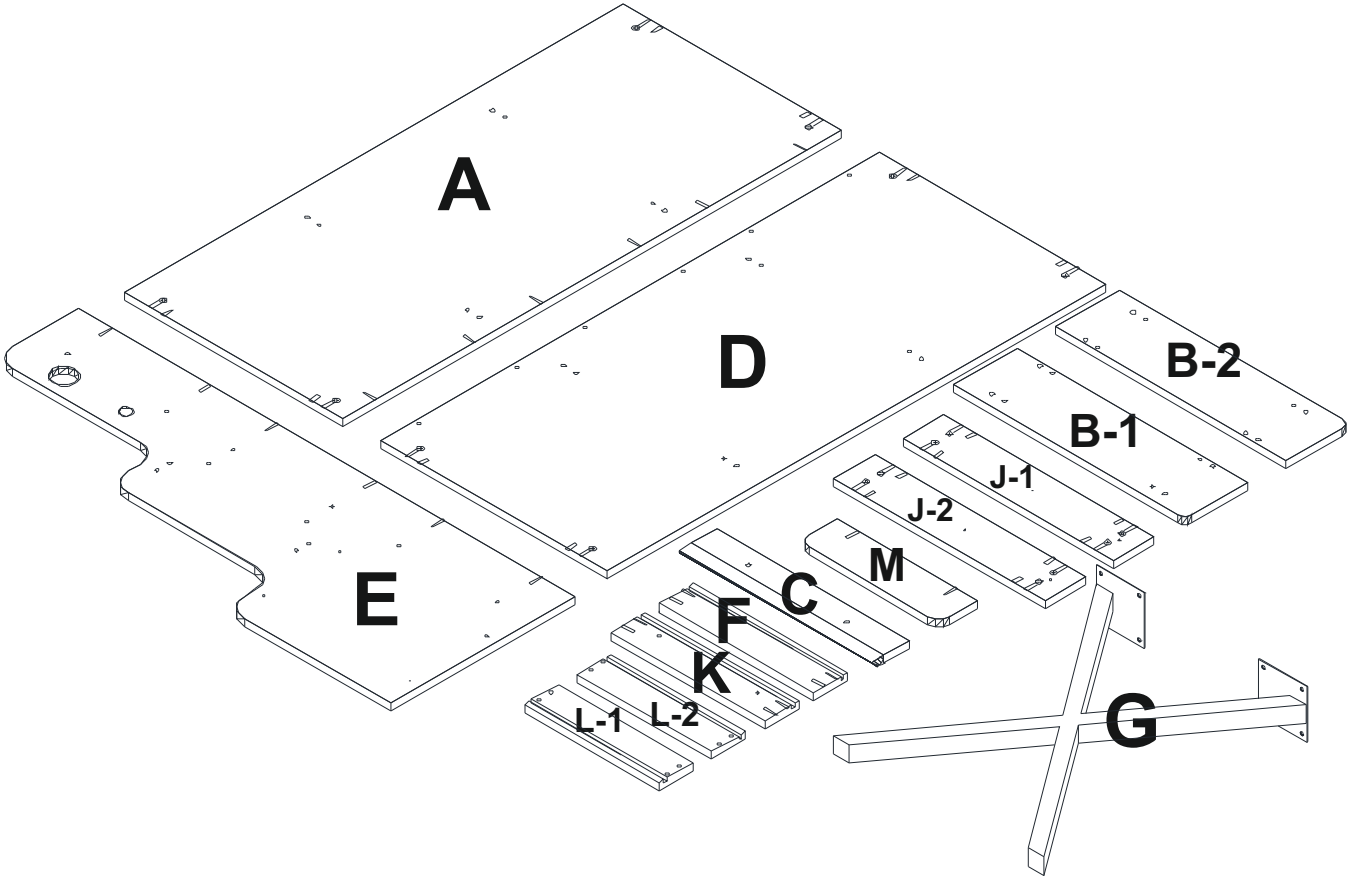

MONTAJ İÇİN GEREKLİ ALET ÖNERİLERİ: Şarjlı matkap, Yıldız başlı tornavida, Çekiç

- A: ÜST TABLA**
- B: SAĞ SOL DIŞ YAN**
- C: ÇEKMECE ÖN**
- D: ALT TABLA**
- E: ARKA PANO**
- F: ÇEKMECE ARKA**
- G: METAL AYAKLAR**
- J: İÇ DİKMELER**
- L: ÇEKMECE YANLAR**
- K: İÇ ÇEKMECE ÖN**
- M: ÜST RAF**

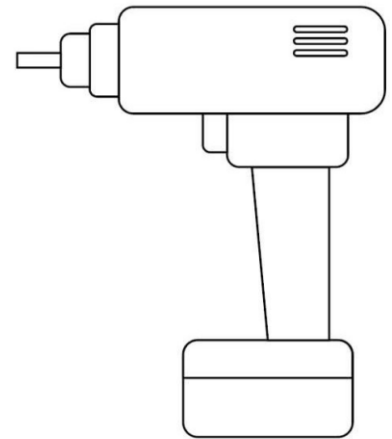
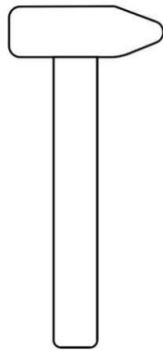

MONTAJ HAZIRLIK: MALZEME POŞET İÇERİĞİ

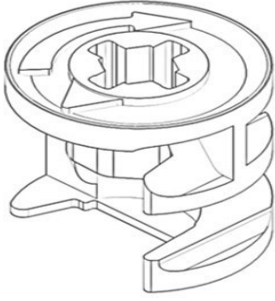

V01

16 ADET MİNİFİX
GÖVDE

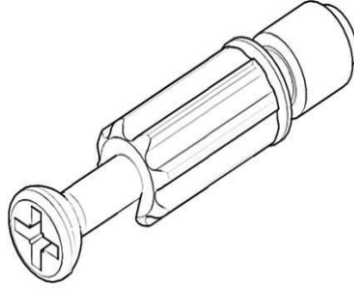

V02

16 ADET MİNİFİX
MİL

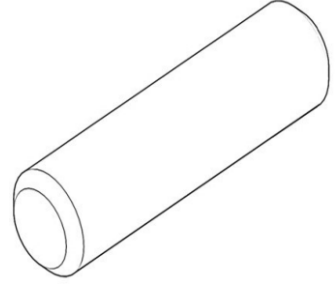

V03

20 ADET PLASTİK
SİYAH KAVELA

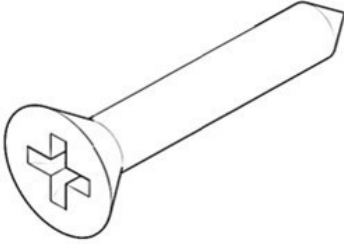

V04

22 ADET
KABİN VİDASI

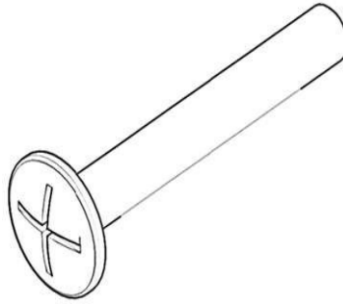

V05

16 ADET
M6X12 YSB VİDA

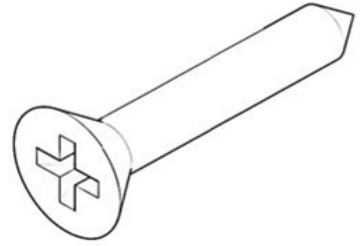

V06

10 ADET
3,5*18 VİDA

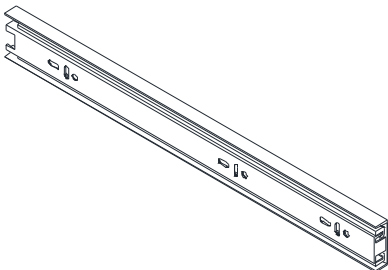

V07

1 TAKIM
350 MM TELESKOBİK RAY

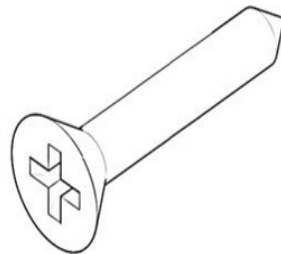

V08

4 ADET
3,5*25 SİYAH VİDASI

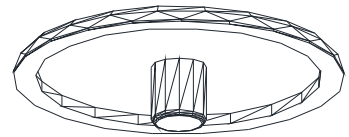

V09

16 ADET
MİNİFİX TIPASI

MONTAJ HAZIRLIK: MALZEME POŞET İÇERİĞİ

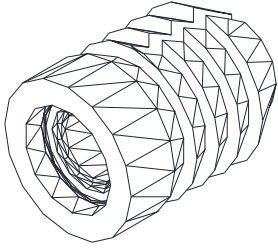

V10

18 ADET
10X10 DUBEL

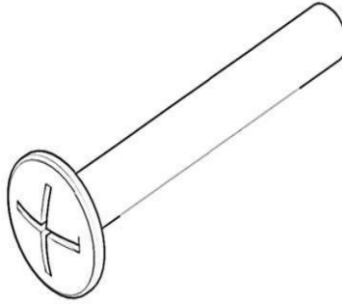

V11

6 ADET
M6X25 YSB VİDA

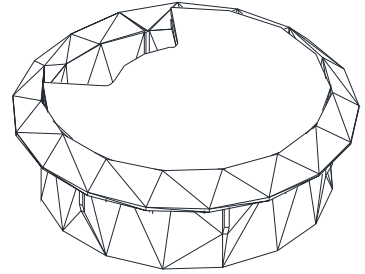

V12

1 ADET
KABLO KANALI

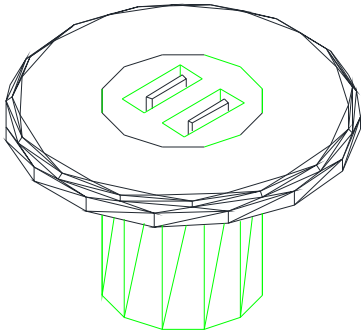

V13

1 ADET
USB ŞARJ SETİ

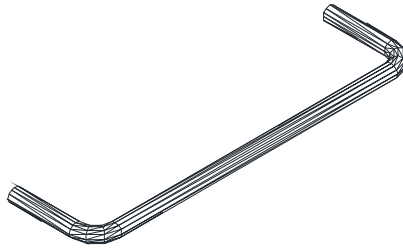

V14

2 ADET
U-BORU

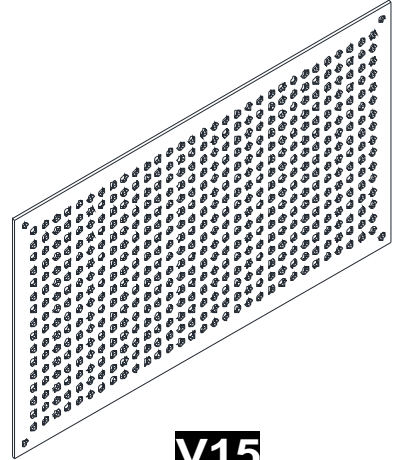

V15

1 ADET
SİYAH DELİKLİ SaÇ

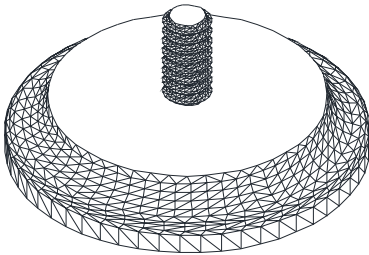

V16

4 ADET
METAL AYAK PATİK

V17

V18

MONTAJ AŞAMALARI - 1

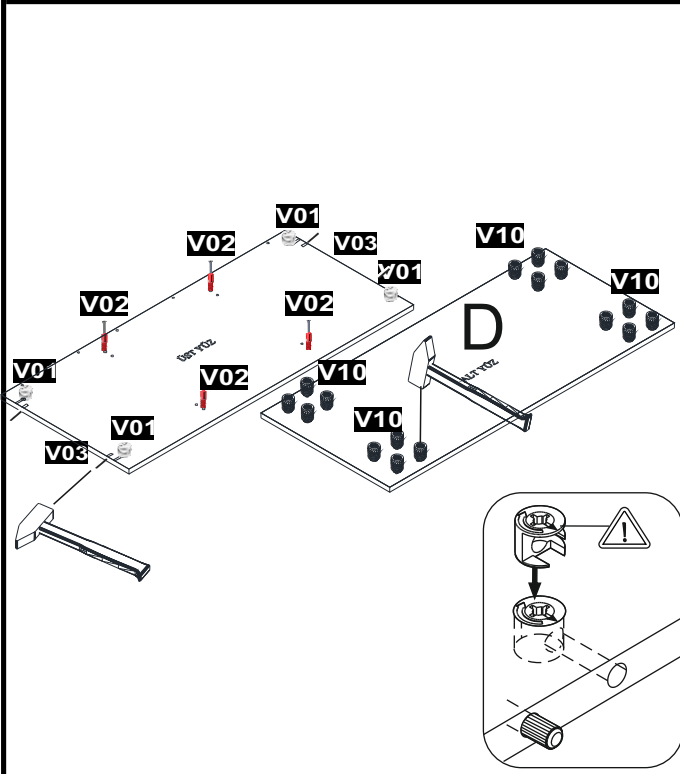

İLK OLARAK **D** PARÇASININ **V01, V02 VE V03** KODLU MALZEMELERİ TAKINIZ. ARDINDAN ALT YÜZÜNE **V10** KODLU MALZEMEYİ (DUBEL) ÇAKINIZ.

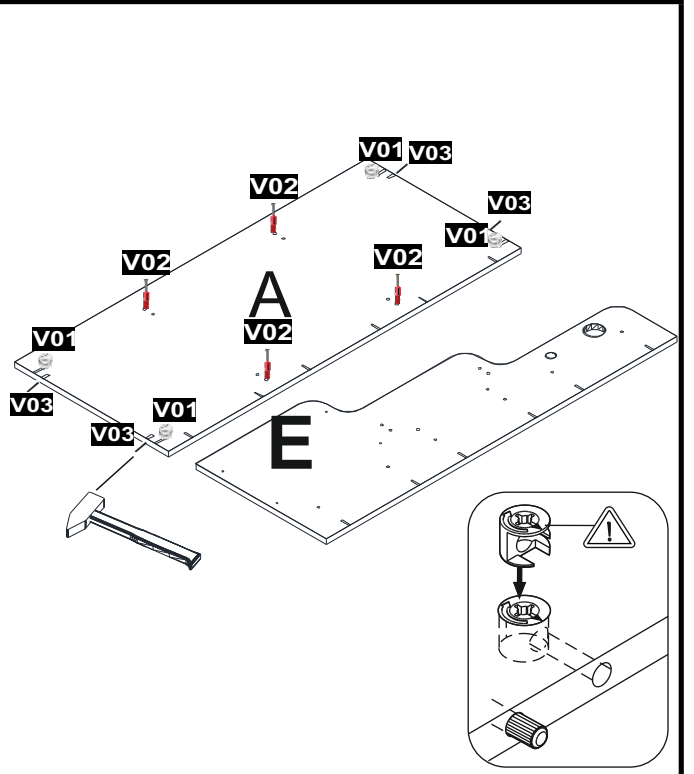

2 AŞAMA **A** PARÇASININ **V01, V02 VE V03** KODLU MALZEMELERİ TAKINIZ..

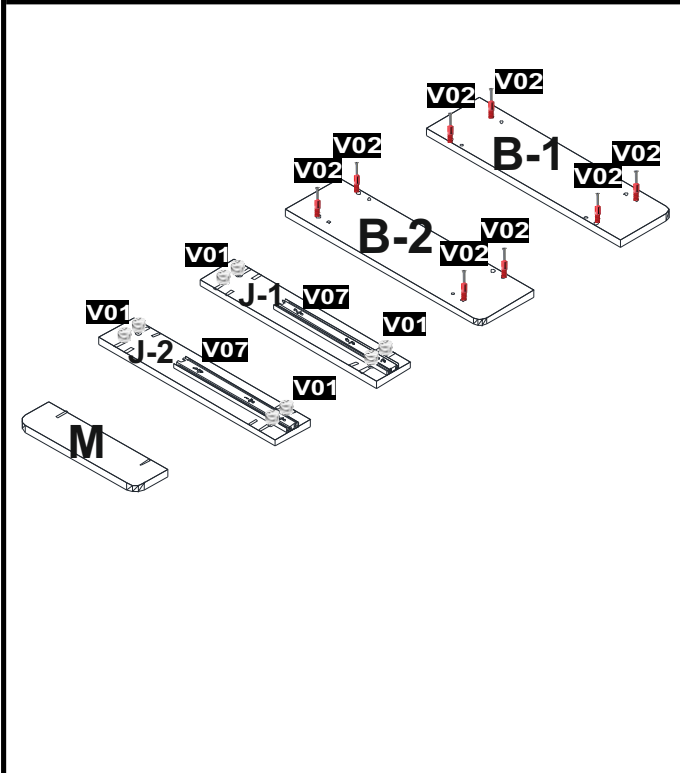

B-1, B-2, J-1, J-2, M PARÇALARIN **V01, V02, V07** KODU MALZEMELERİ ÜZERİNE MONTE EDİNİZ....

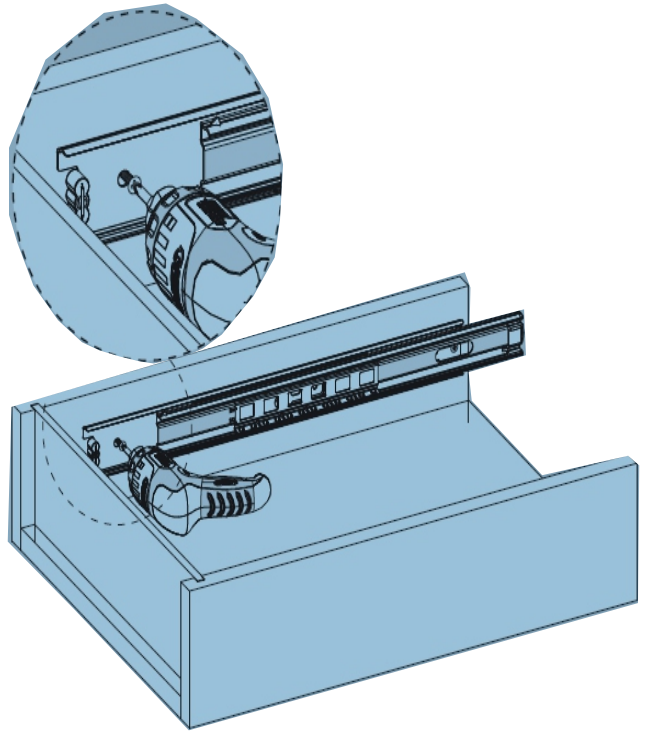

MODÜL YAN ÇEKMECE BAĞLAMA ŞEKLİ. **V06** KODLU MALZEME KULLANINIZ **3,5X18 VİDA**

MONTAJ AŞAMALARI - 2

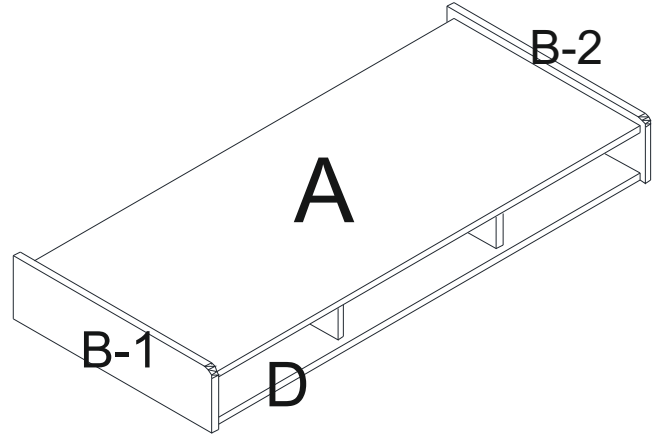
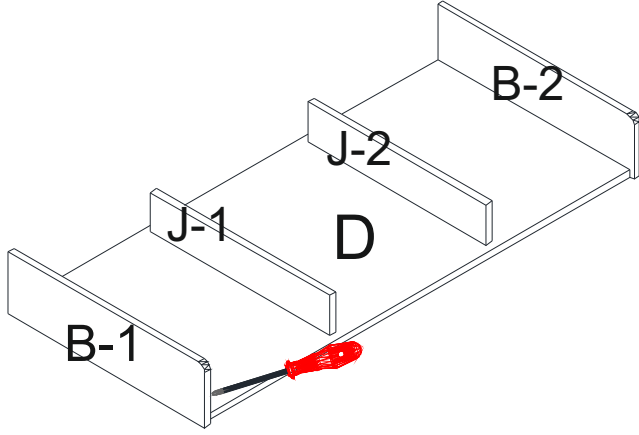

1 AŞAMA **D,B-1-2,J-1-2** KODLU MALZEMELERİN MONTAJINA SIRALAMAYA GÖRE BAŞLAYINIZ.

2 AŞAMA İSE **E** KODLU PARÇAYI (ÜST TABLA) ÜZERİNE KOYARAK KUTU HALİNE GETİRİNİZ.

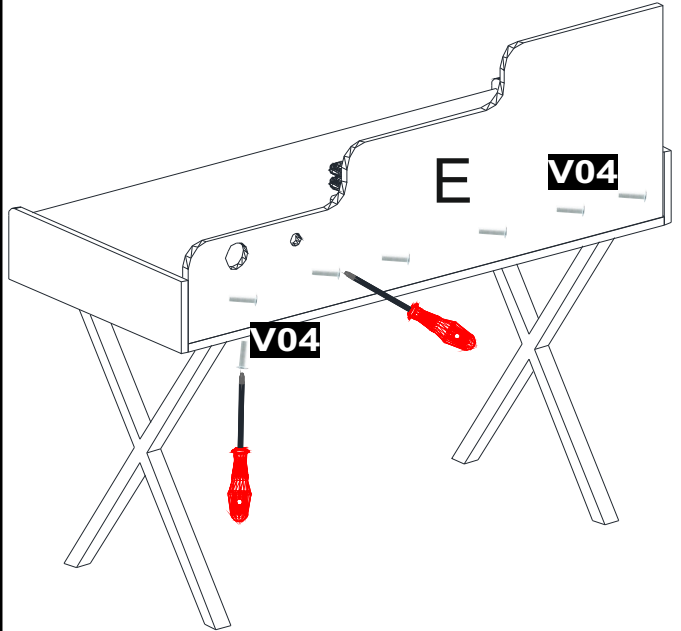
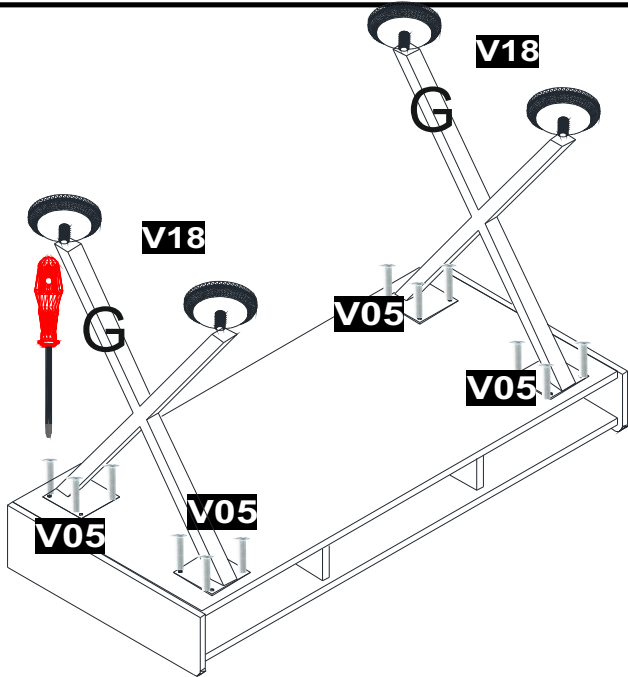

MODÜL KUTU HALİNE GETİRİLDİKTEN SONRA **G** KODLU METAL AYAK. **V05** KODU ŞARJLI MATKAP İLE BAĞLAYINIZ

E PARÇASINI ŞEKİLDE GÖRÜLDÜĞÜ GİBİ **V04** KODLU MALZEME (KABİN VİDASI) İLE ŞARJLI MATKAP YARDIMI İLE BAĞLAYINIZ.

MONTAJ AŞAMALARI - 3

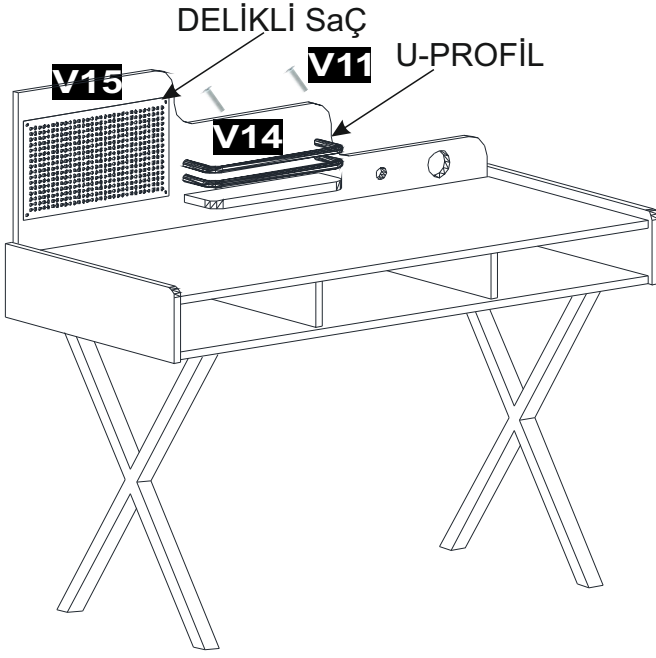

E PARÇASININ ŞEKİLDE GÖRÜLDÜĞÜ **V14-V15** ÖN KISMINDA OLACAK ŞEKİLDE MONTAJINI YAPINIZ.

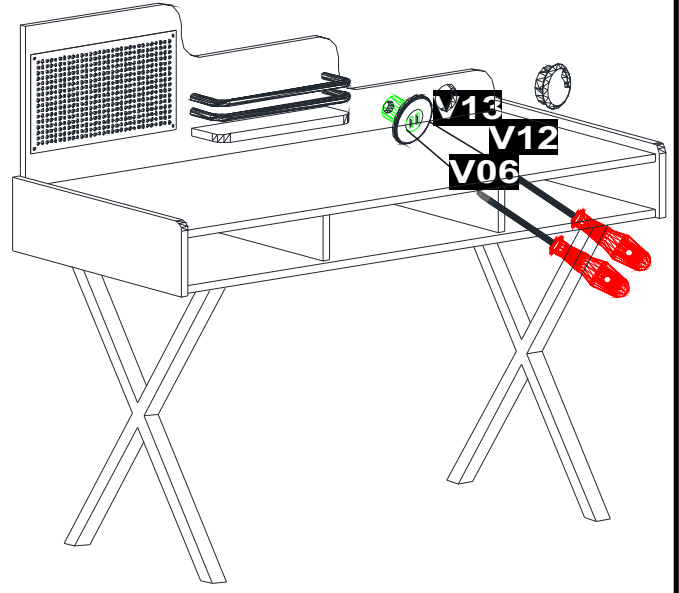

ÇALIŞMA MASASI MONTAJI SON ADIMINDA MASA ARKA PANOSUNDA BULUNAN DELİKLERE KABLO KANALI VE USB SETİ TAKINIZ. ARDINDAN USB SETİ ÜSTÜNDE BULUNAN KAPAĞI ÇIKARINIZ VE ÜZERİNDE BULUNAN DELİKLERDEN 3,5X18 VİDA İLE VIDALAYINIZ. SON OLARAK LED KANALININ VE USB SETİN FİŞLERİNİ PRİZE TAKINIZ.

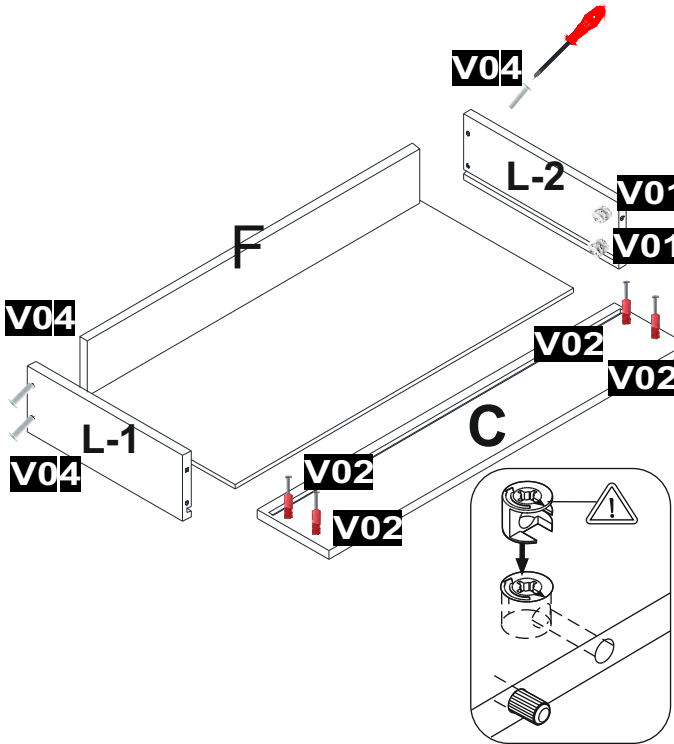

ŞEKİLDE GÖRÜLDÜĞÜ GİBİ **C** PARÇASINA **V02** KODLU MALZEMEYİ TAKINIZ. ARDINDAN **L-1** VE **L-2** PARÇALARINI **C** PARÇASINA TAKINIZ. DAHA SONRA KANALLARDAN ARKALIK PARÇASINI GEÇİRİNİZ. SON OLARAK **F** PARÇASINI **V04** KODLU MALZEMELER İLE BİRLEŞTİRİNİZ.

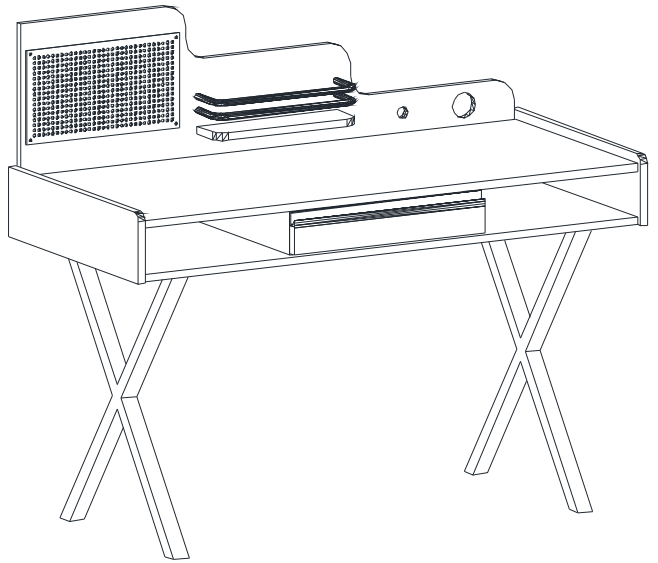

MODÜLÜN BİTMİŞ HALİ.